

Area		JAPAN	NORTH AMERICA	NORTH AMERICA DERIVATIVE	EUROPE	GENERAL AREA	CHINA
Model Name		K-75XR90M2	K-75XR90M2	K-75XR90CM2	K-75XR95M2	K-75XR90M2	K-75XR90M2
SV No.		SV-44400	SV-44289	SV-44288	SV-44390	SV-44326	SV-44373
DIMENSION	TV only (W x H x D)	-	-	-	-	-	-
	TV only with camera (W x H x D)	166.9 x 95.2 x 4.3 (4.6) cm	1669 x 952 x 43 (46) mm / 65 3/4 x 37 1/2 x 1 3/4 (1 13/16) inch	1669 x 952 x 43 (46) mm / 65 3/4 x 37 1/2 x 1 3/4 (1 13/16) inch	Approx. 166.9 x 95.2 x 4.3 (4.6) cm	Approx. 1669 x 952 x 43 (46) mm	Approx. 1669 x 952 x 43 (46) mm
	TV with Stand (Standard position) (W x H x D)	166.9 x 103.3 x 38.6 cm	1669 x 1033 x 386 mm / 65 3/4 x 40 3/4 x 15 1/4 inch	1669 x 1033 x 386 mm / 65 3/4 x 40 3/4 x 15 1/4 inch	Approx. 166.9 x 103.3 x 38.6 cm	Approx. 1669 x 1033 x 386 mm	Approx. 1669 x 1033 x 386 mm
	TV with Stand (Sound bar position) (W x H x D)	-	-	-	-	-	-
	TV with Stand (Outside) (W x H x D)	-	-	-	-	-	-
	TV with Stand (Inside) (W x H x D)	-	-	-	-	-	-
	TV with Stand (Outside for Soundbar) (W x H x D)	-	-	-	-	-	-
	TV with Stand (Inside for Soundbar) (W x H x D)	-	-	-	-	-	-
	TV with Stand (Narrow position) (W x H x D)	-	-	-	-	-	-
	Stand Width (Standard position)	34.3 cm	343 mm / 13 5/8 inch	343 mm / 13 5/8 inch	Approx. 34.3 cm	Approx. 343 mm	Approx. 343 mm
	Stand Width (Sound bar position)	-	-	-	-	-	-
	Stand Width (Outside)	-	-	-	-	-	-
	Stand Width (Inside)	-	-	-	-	-	-
	Stand Width (Narrow position)	-	-	-	-	-	-
Stand Inner Distance	-	-	-	-	-	-	
Stand Inner Distance (Inside position)	-	-	-	-	-	-	
Stand Inner Distance (Outside position)	-	-	-	-	-	-	
Dimension of Stand (W x H x D)	34.3 x 8.1 x 38.6 cm	343 x 81 x 386 mm / 13 5/8 x 3 1/4 x 15 1/4 inch	343 x 81 x 386 mm / 13 5/8 x 3 1/4 x 15 1/4 inch	Approx. 34.3 x 8.1 x 38.6 cm	Approx. 343 x 81 x 386 mm	Approx. 343 x 81 x 386 mm	
Dimension of Stand (Low) (W x H x D)	-	-	-	-	-	-	
Dimension of Stand (High) (W x H x D)	-	-	-	-	-	-	
VESA Hole Pitch	30.0 x 30.0 cm	300 x 300 mm / 11 7/8 x 11 7/8 inch	300 x 300 mm / 11 7/8 x 11 7/8 inch	30.0 x 30.0 cm	300 x 300 mm	300 x 300 mm	
WEIGHT	TV Only	38.1 kg	38.1 kg / 84 lb	38.1 kg / 84 lb	Approx. 38.1 kg	Approx. 38.1 kg	Approx. 38.1 kg
	TV with Stand	43.5 kg	43.5 kg / 95.9 lb	43.5 kg / 95.9 lb	Approx. 43.5 kg	Approx. 43.5 kg	Approx. 43.5 kg
Remarks		1 way	1 way	1 way	1 way	1 way	1 way

TV with Stand

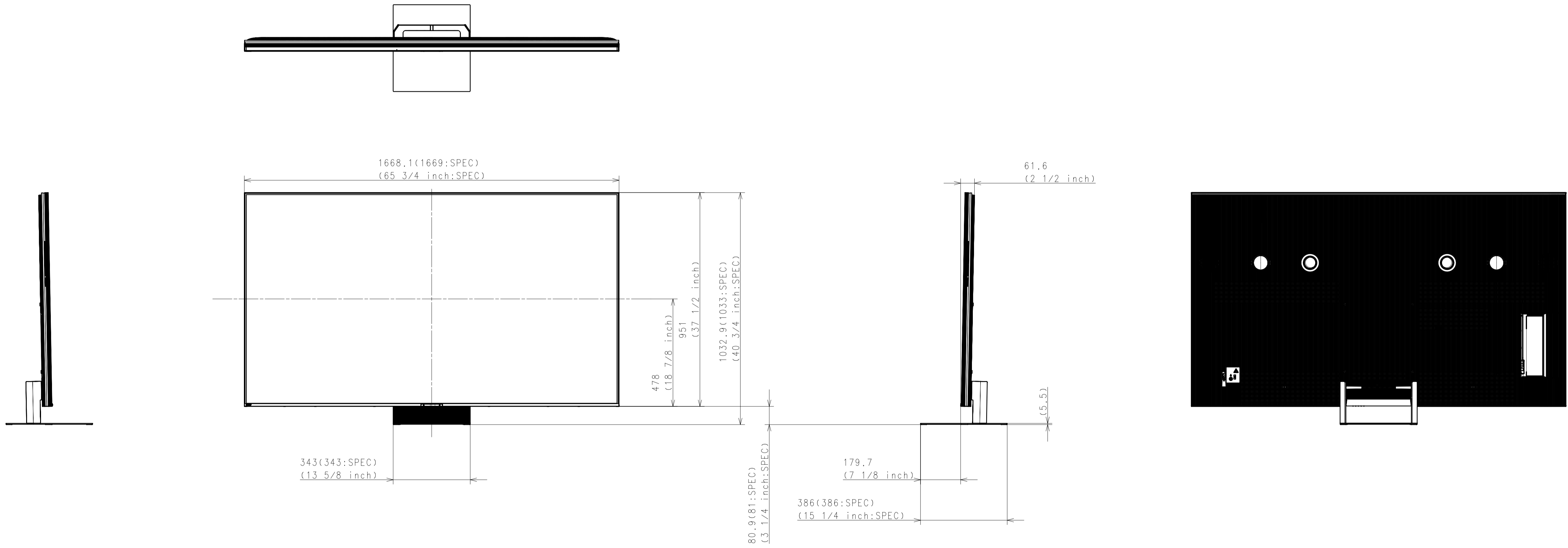

Purchase recycled resins and wire rods only from the business partners that Sony approves as Green Partners.

<p>△A</p> <p>△B</p> <p>△C</p> <p>△D</p> <p>△E</p> <p>△F</p> <p>△G</p> <p>△H</p> <p>△I</p> <p>△J</p> <p>△K</p> <p>△L</p>	<p>DATE OF ISSUE</p> <p>2025.12.26</p> <p>DOCUMENT TYPE</p> <p>ASSEMBLY DRAWING</p> <p>(JIS & ISO/IEC JIS 0015)</p>
<p>HISTORY</p> <p>NO.</p> <p>COUNT</p> <p>SUFFIX</p> <p>REV. NO.</p> <p>DATE</p> <p>RELEASE NO.</p> <p>DATE</p> <p>REVISION</p> <p>SIGN.</p>	<p>MATERIAL COLOR</p> <p>FINISH COLOR</p>
<p>LEGAL OWNER</p> <p>Sony Corporation</p> <p>RESPONSIBLE DEPARTMENT</p> <p>DTC_MD div1 MD dept6</p> <p>PLANNED BY</p> <p>2025.12.26</p> <p>DESIGNED BY</p> <p>2025.12.26</p> <p>DRAWN BY</p> <p>2025.12.26</p>	<p>ORIGINAL MODEL</p> <p>75 (XR90M2) EXTERIOR VIEW</p> <p>TENTATIVE MODEL</p> <p>75 (XR90M2) EXTERIOR VIEW</p> <p>SCALE</p> <p>1:10</p> <p>SIZE</p> <p>A1</p> <p>UNIT</p> <p>mm</p> <p>SHEET/PAGES</p> <p>1 / 4</p>

TV only

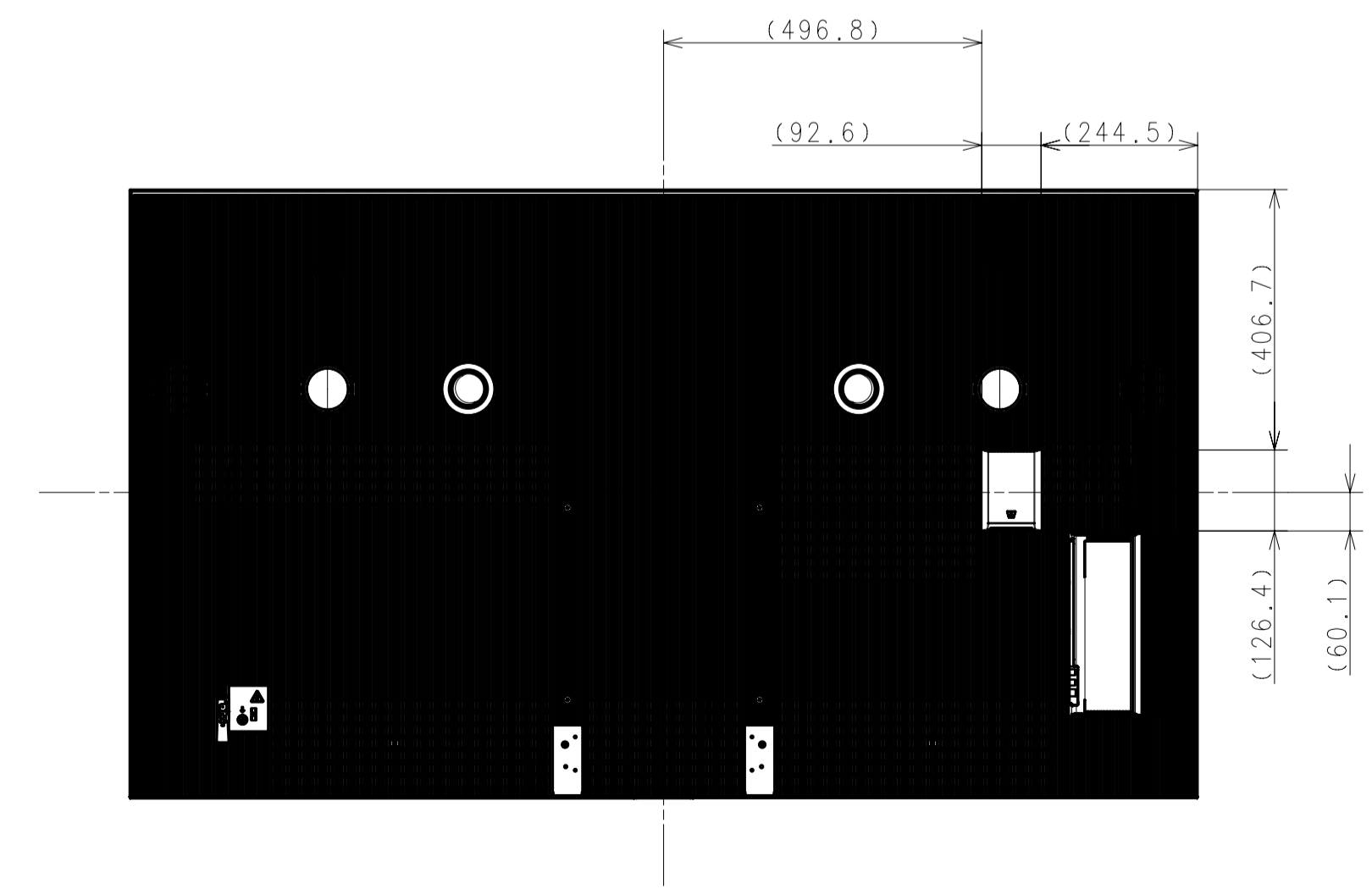
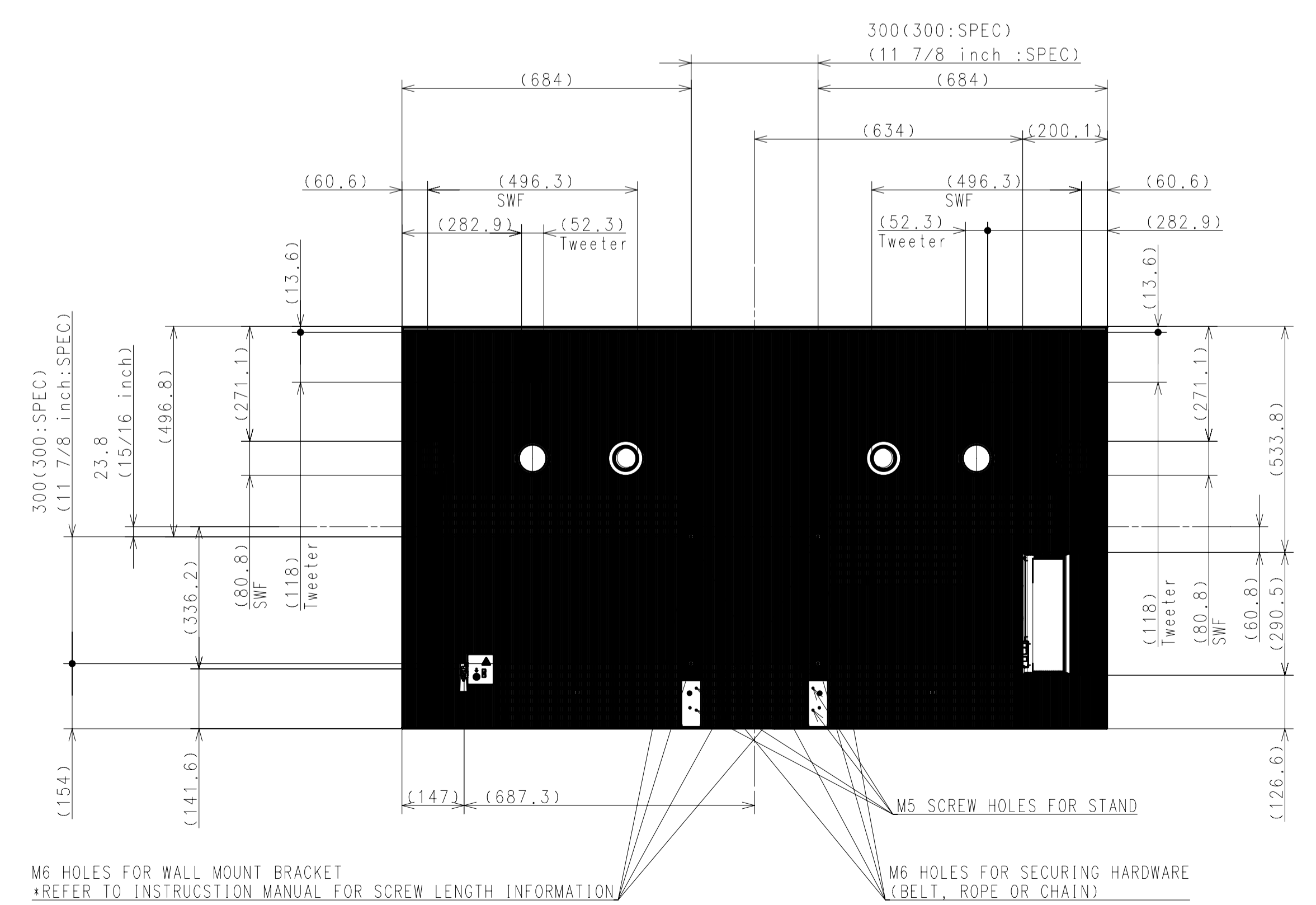
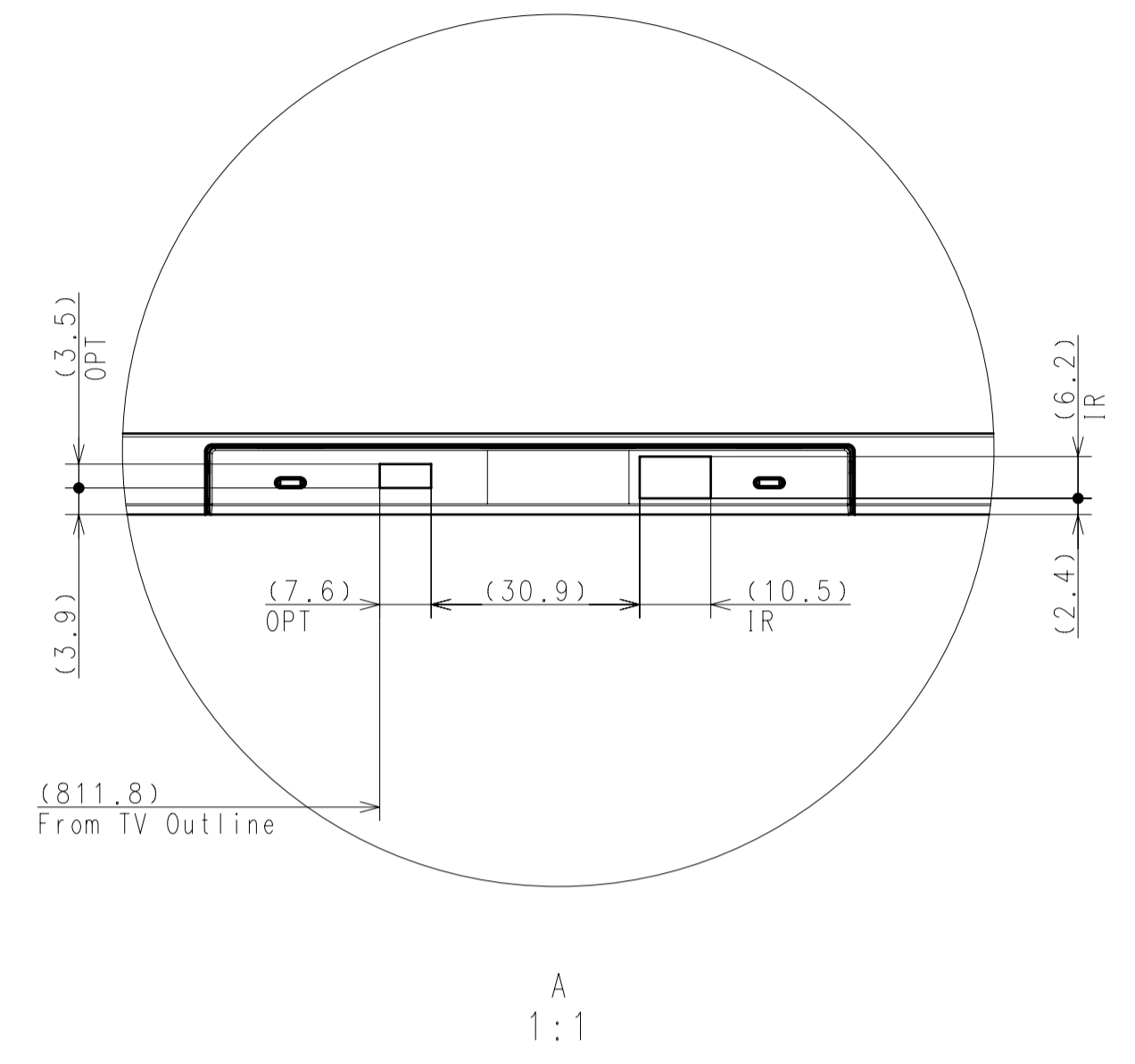
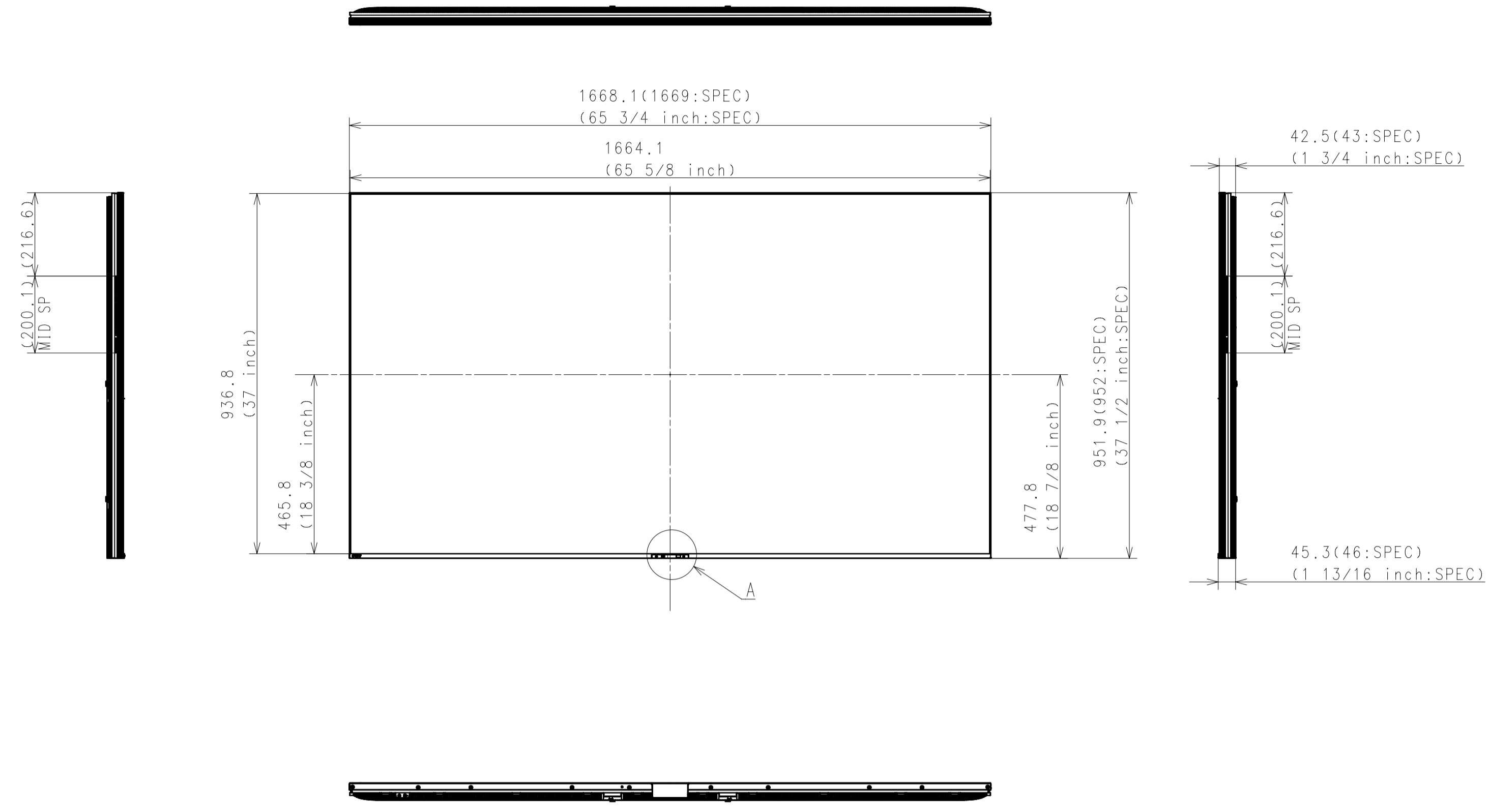

M6 HOLES FOR WALL MOUNT BRACKET
 *REFER TO INSTRUCTION MANUAL FOR SCREW LENGTH INFORMATION

FOR EXCEPT EUROPE

FOR EUROPE

DESCRIPTION 1	75 (XR90M2) EXTERIOR VIEW	LEGAL OWNER	Sony Corporation	SCALE	1:10
DESCRIPTION 2	75 (XR90M2) EXTERIOR VIEW	PART NO.		SHEET/PAGES	2 / 4

SU WL-450

STANDARD

SLIM

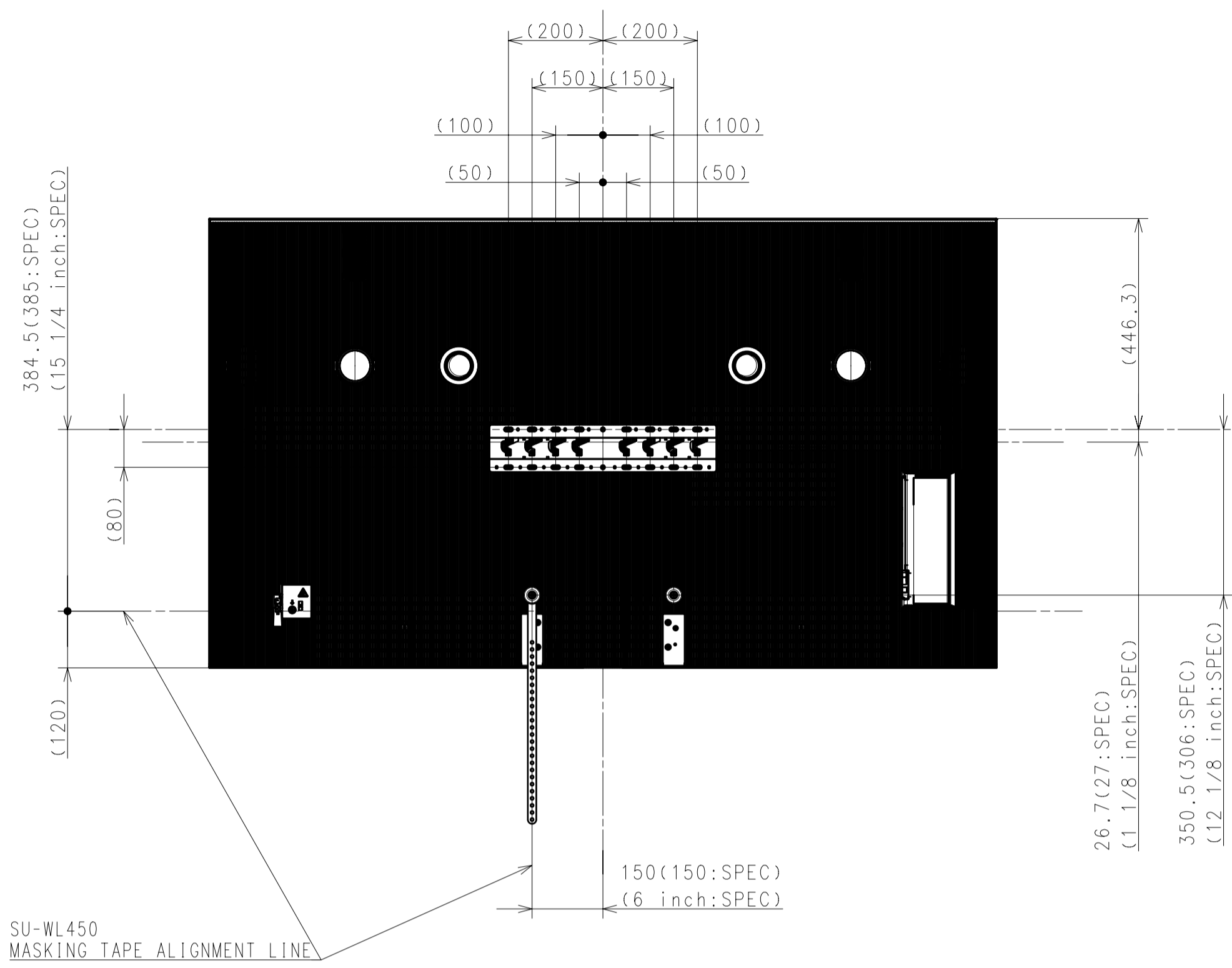

104.6(105:SPEC)
(4 1/4 inch:SPEC)

62.8(63:SPEC)
(2 1/2 inch:SPEC)

504.5(505:SPEC)
(20 inch:SPEC)

504.5(505:SPEC)
(20 inch:SPEC)

DESCRIPTION 1	LEGAL OWNER	SCALE
75 (XR90M2) EXTERIOR VIEW	Sony Corporation	1:10
DESCRIPTION 2	PART NO.	SHEET/PAGES
75 (XR90M2) EXTERIOR VIEW		3 / 4

SU WL-900

SU WL-950

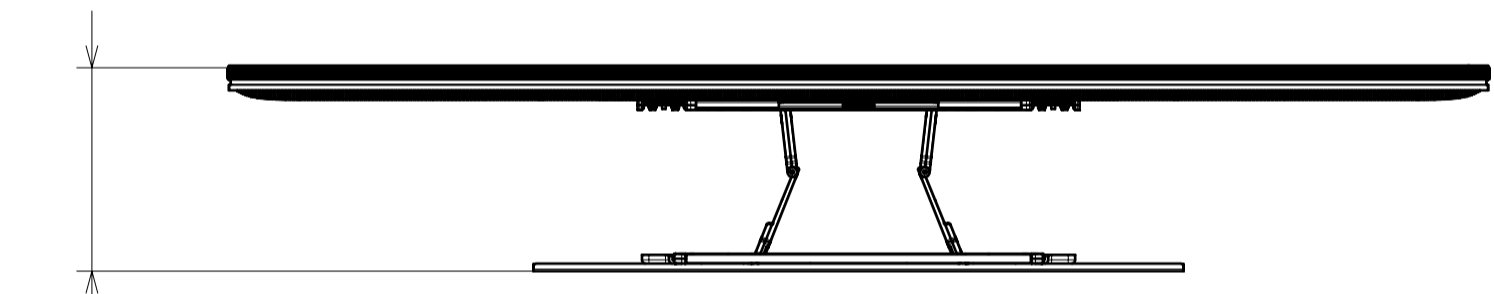
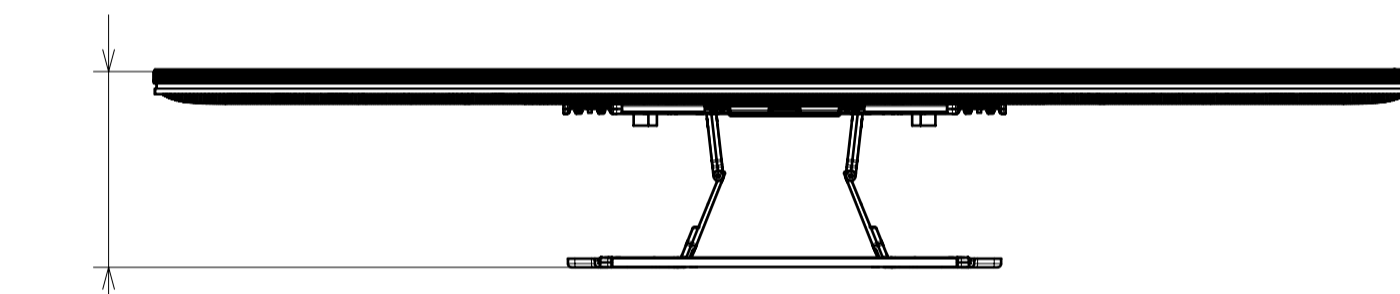
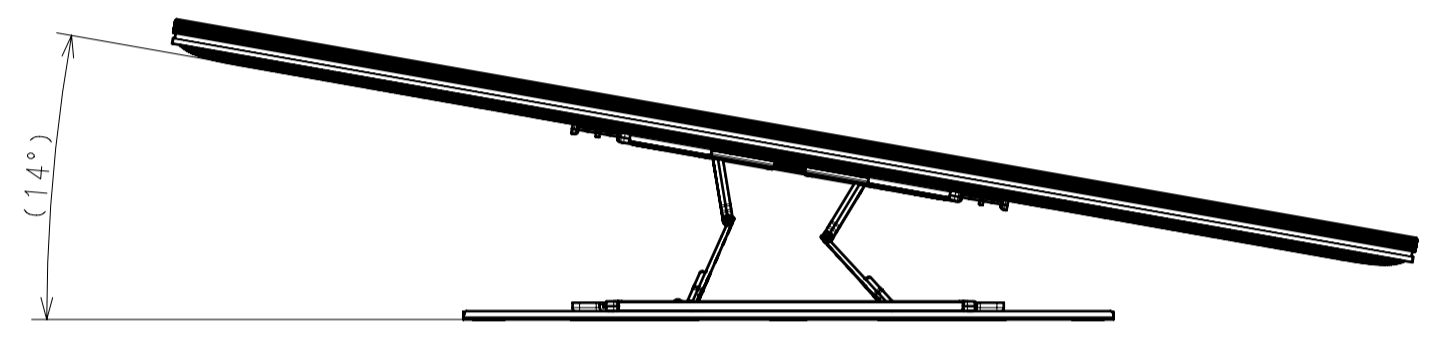
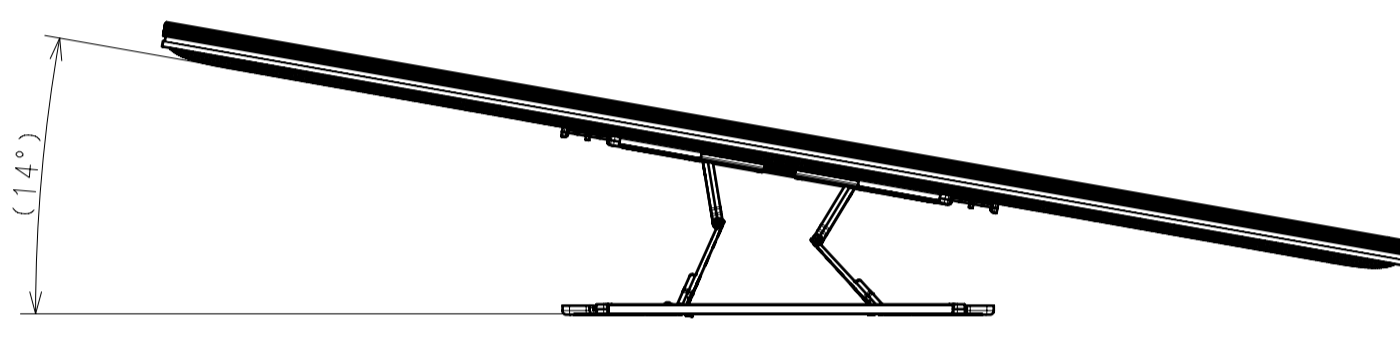
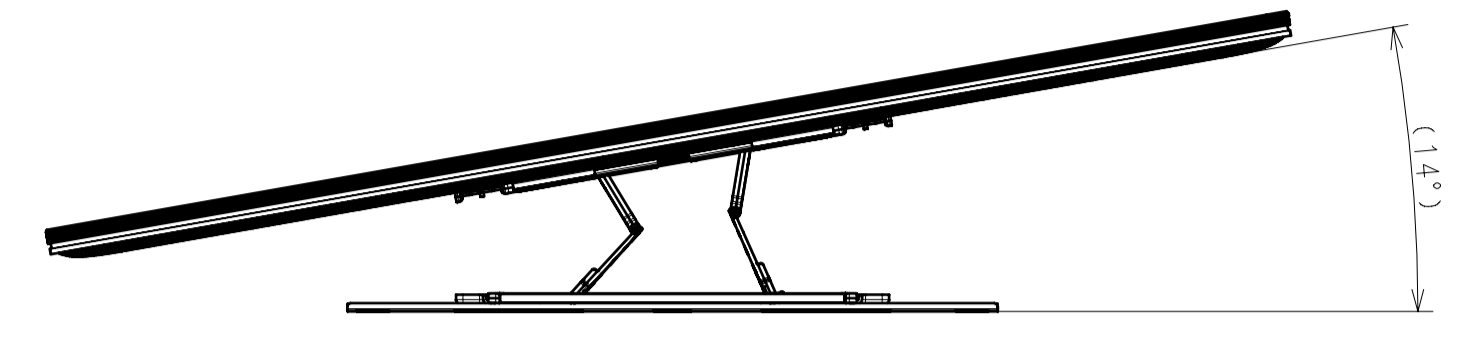
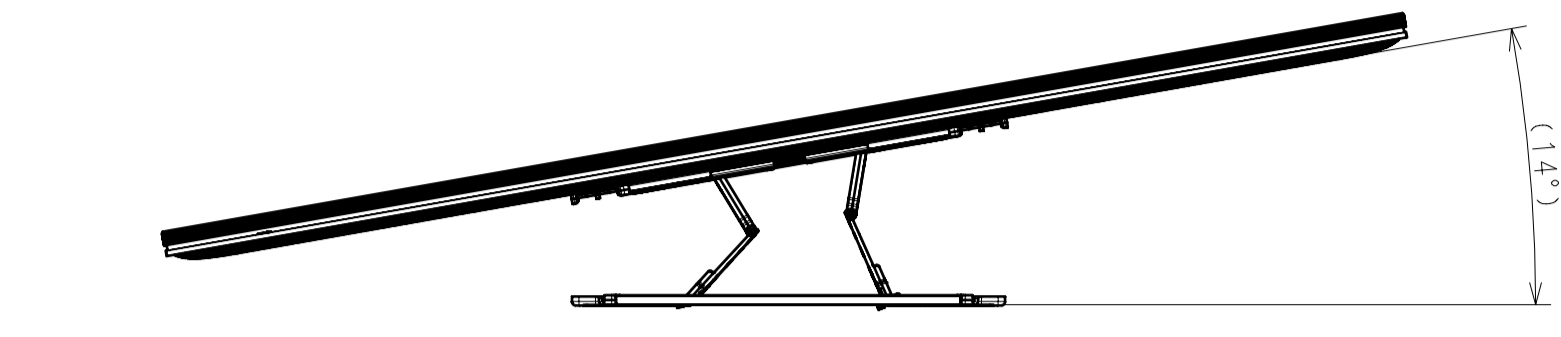

STANDARD

SLIM

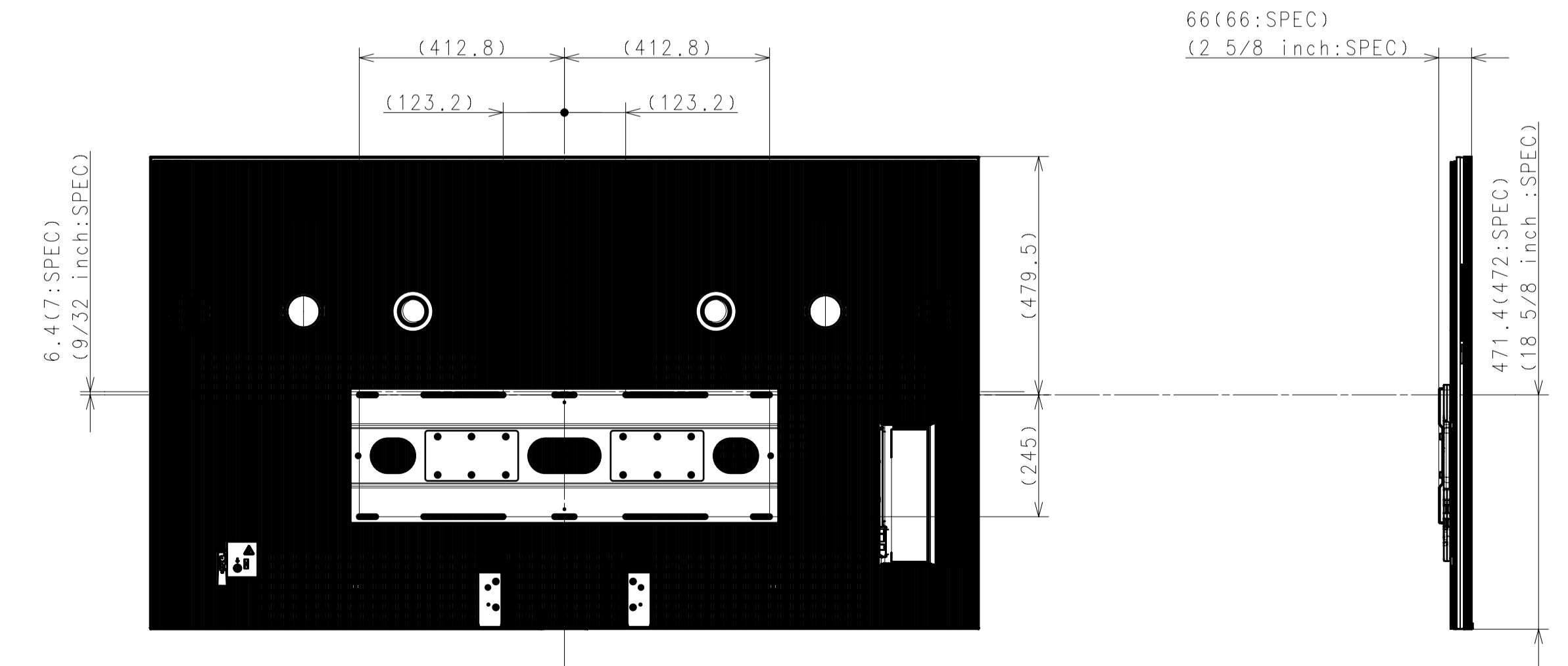
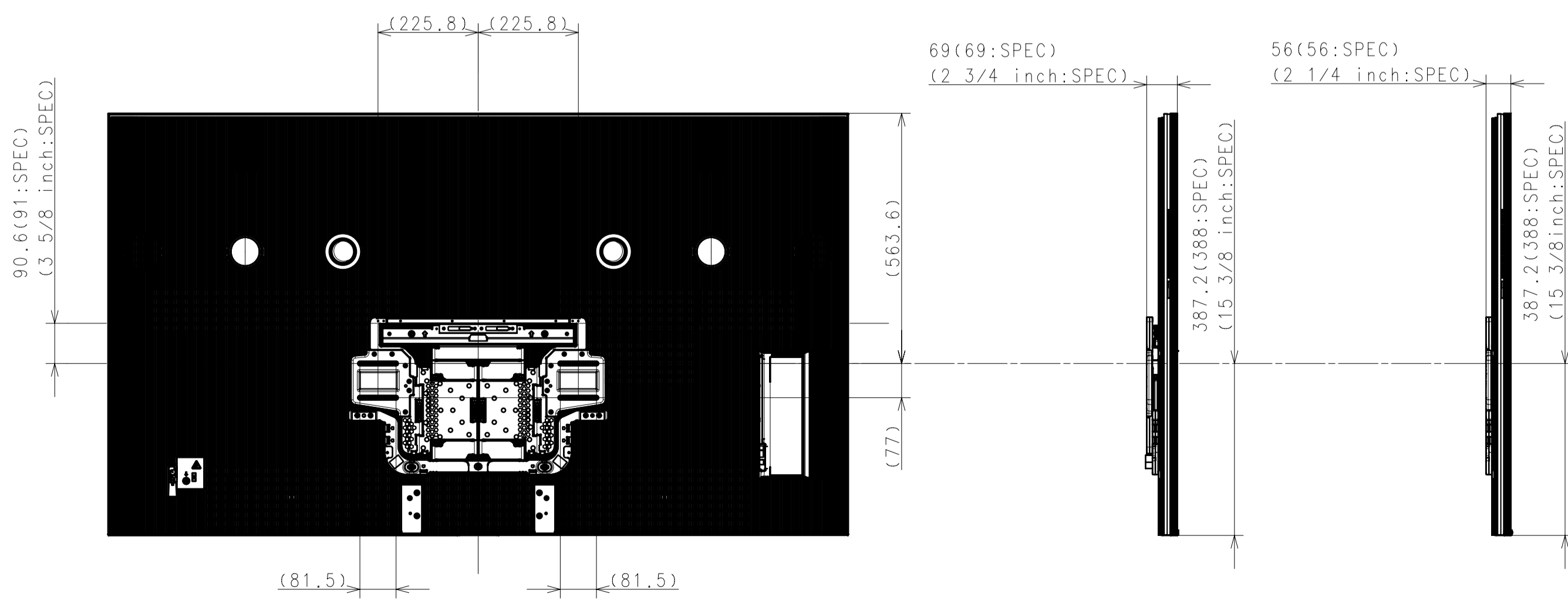

DESCRIPTION 1	75 (XR90M2) EXTERIOR VIEW	LEGAL OWNER	Sony Corporation	SCALE	1:10
DESCRIPTION 2	75 (XR90M2) EXTERIOR VIEW	PART NO.		SHEET/PAGES	4 / 4